

TRANSCRIPTORS LTD

**the hydraulic
reference turntable
manual**

TRANSCRIPTORS

Record Playing Equipment

The TRANSCRIPTOR Hydraulic Reference Turntable and associated Fluid Arm represent the very latest in record player engineering techniques and are designed to complement the finest stereo reproducing equipment. The complete unit is free-standing on three adjustable acoustic feedback damping legs.

TRANSCRIPTORS LTD

2 Theobald Street

Boreham Wood Hertfordshire England

Tel. 01-953 0771

TRANSCRIPTOR

Hydraulic Reference Turntable

The Hydraulic Reference Turntable employs a low-speed, recoil start synchronous motor on a double-deck spring mounting driving the platter via a rubber belt, thereby providing complete vibration insulation. The main bearing incorporates a silicone fluid filled well rotating at the same speed as the platter, fine speed control being provided by a static vane immersed in the fluid. Platter speed is therefore determined by the a.c. mains frequency, which is effectively constant, and the viscous fluid flow onto the vane, also effectively constant. Speed changing (45 r.p.m. and $33\frac{1}{3}$ r.p.m.) is accomplished by moving the drive belt from one motor pulley to the other and a neon-lit stroboscope is provided for accurate speed setting.

In order to eliminate completely any mechanical shock to the equipment, on/off switching of the drive motor is accomplished by means of a magnetically-actuated vacuum switch. The sintered gold contacts on this switch guarantee an extremely long operational life.

The Hydraulic Reference Turntable also has provision for the unique TRANSCRIPTOR Sweep Arm representing a great advance in the field of record cleaning devices. This consists of a fine squirrel hair brush mounted on a balanced beam so that the brush tracks the record at a downward force of less than 1 gramme. Thus, the use of the Sweep Arm ensures that the record is cleaned thoroughly whilst in use without producing any wear on the record or causing any noticeable amount of static.

A swinging squirrel hair brush is also available as an accessory for cleaning dust from the stylus assembly.

TRANSCRIPTOR

Fluid Arm

The Fluid Arm has been developed specifically for use with modern cartridges of not more than 16 grammes weight, tracking at not more than 2 grammes.

The Fluid Arm employs a unipivot working in an oil-filled well, so that the arm beam assembly relies for its lateral support, stability and resonant damping on the fluid surrounding the pivot. This results in a substantially friction-free pivot of high stability.

An adjustable eccentric counterweight allows both lateral and longitudinal balancing of the arm. Fine control of longitudinal balancing to allow adjustment of the stylus tracking force within a fraction of a gramme is provided by a screwed counterweight.

NOTE: TRANSCRIPTORS LTD can supply a stylus scales set designed to measure the downward force of any pickup arm assembly tracking at 5 grammes or less to an accuracy of ± 50 milligrammes.

Also provided is a bias compensating device so designed as to use a rolling motion. An adjustable bias weight operating through a pulley gives correct compensation as the stylus moves towards the centre of the record.

A lifting and positioning (or "cueing") device is provided incorporating a hydraulic lowering handwheel which lowers the arm onto the record automatically, but which can be over-ridden when required for accurate manual positioning.

A plug-in headshell is fitted for mounting the cartridge, no soldering is required, and the signal outputs are taken via a pair of 3-feet (914 mm) long screened leads terminated in co-axial plugs.

SPECIFICATION

Hydraulic Reference Turntable

Platter	12 in. (305 mm) diameter cast and machined aluminium alloy disc fitted with six gold-plated brass weights. Total weight 11 lb. (5 kilogrammes) statically balanced to within 3 grammes. The record is supported on soft rubber pads thereby reducing rumble and induced static to an absolute minimum.
Main bearing	Slim section ball-ended ground and polished steel spindle running onto a hardened steel thrust pad and into PTFE bushes (PTFE is a plastic material having a lower coefficient of friction than any other solid, and requires no lubricating).
Motor	Single-phase synchronous, recoil start.
Power requirement	115V or 240V, single-phase, 50 Hz or 60 Hz. Fused on the turntable at 1A.
Speeds	33 $\frac{1}{3}$ and 45 r.p.m.
Speed control	$\pm 2\%$ of nominal.
Speed indication	Neon-lit stroboscope geared up 6 : 1 to give a 6° reading for a 1° variation in platter speed.
Wow and flutter	0.01% at 33 $\frac{1}{3}$ r.p.m.
Rumble	Not measurable.
Dimensions	Width 17 $\frac{1}{4}$ in. (438 mm) Depth (lid closed) 17 in. (432 mm) Depth (lid open) 21 $\frac{1}{4}$ in. (540 mm) Height (lid closed) 7 in. (178 mm) Height (lid open) 20 in. (508 mm)

SPECIFICATION

Fluid Arm

Length	9 in. (229 mm) or 10 in (254 mm)	
Fixing	Single hole, 1 in. (25 mm) diameter.	
Adjustment	Vertical: $2\frac{1}{2}$ in. (64 mm) Horizontal (all planes): $\frac{1}{2}$ in. (13 mm)	
Principal dimensions:	9 in. (229 mm) arm	10 in. (254 mm) arm
Counterweight overhang	3 in. (76 mm)	$3\frac{1}{2}$ in. (82 mm)
Overall length	12 in. (305 mm)	13 in. (330 mm)
Pivot to turntable centre	$8\frac{1}{2}$ in. (216 mm)	$9\frac{1}{2}$ in. (241 mm)
Lead capacitance	65 pF/ft.	
Cartridge type	Not greater than 16 grammes in weight, tracking at not more than 2 grammes, with $\frac{1}{2}$ in. (13 mm) fixing centres. Compliance for 9 in. (229 mm) arms between 20 and 48×10^{-9} cm dyne and for 10 in. (254 mm) arms between 15 and 30×10^{-9} cm dyne.	
Resonance of arm	This is a function of cartridge compliance and weight, but for cartridges of between 3 and 14 grammes weight it will lie between 8 Hz and 24 Hz.	

NOTE: Neither TRANSCRIPTOR Fluid Arm is suitable for cartridges having a compliance of less than 15×10^{-6} cm dyne as this is likely to cause secondary resonance in the arm tube.

The often held opinion that 12 in. (305 mm) arms with their admittedly lower tracking error, are superior to shorter arms, is inherited from the days when cartridges were of low compliance, and heavy arms were in any case required in order to keep the resonance of the system low. Resonance is that frequency at which an arm-cartridge assembly, the stylus of which is on the record, will spring up and down or from side to side on the spring of the stylus assembly. A modern high compliance cartridge (very compliant, or soft and springy) mounted in a heavy arm will have a resonance of a very low frequency, possibly in the warp or ripple frequency of the records, with modern cartridges the aim is to obtain an arm light enough to give a system resonance high enough to be useable. It is not only lightness of mass that is required but low mass effective at the stylus, and this mass is the moment of inertia of the system about the pivot, divided by the square of the distance of the pivot from the stylus, and similar mathematics apply at the counterweight end of the tone arm. Albeit 12 in. (305 mm) arms have a disproportionately high effective mass at the stylus point, and should be avoided wherever possible. Manufacturers can hardly be blamed for selling 12 in. (305 mm) arms in quantity today, as the above facts are rarely known or understood by the purchaser of a long arm which will give totally unsatisfactory results with a highly compliant cartridge designed for shorter arms. As compliance rises to 60 or 80×10^{-6} cm dyne, arms will become shorter and shorter, and at 90×10^{-6} cm dyne will require a vestigial arm of 4 in. (102 mm) or less, no doubt mounted on some radial tracking device yet to come.

SPECIFICATION

Stylus Scales

Range	0–5 grammes
Accuracy	±50 milligrammes
Weights supplied	2 grammes (2 off) 1 gramme (1 off) 500 milligrammes (1 off) 200 milligrammes (2 off) 100 milligrammes (1 off) 50 milligrammes (1 off)
Dimensions	Length 4 in. (102 mm) Height 1 in. (25 mm)

User Information

After unpacking the equipment and removing all the obvious packing and retaining tape, proceed as follows with the fitting and setting-up instructions.

NOTE: The numbers given in brackets in the following instructions refer to the parts identified in the various illustrations.

Fluid Arm—fitting instructions

If the TRANSCRIPTOR Fluid Arm has not been fitted onto the tone arm board, fig. 2(1), proceed as follows. However, if it has been fitted, proceed with the setting-up instructions.

- 1** Remove the headshell, fig. 1(1) by slackening its knurled retaining nut, supporting the arm with one hand and pulling the headshell off with the other. Fit the cartridge, connecting the terminal wires as marked on the cartridge and underneath the headshell. Refit the headshell to the arm.

- 2** Temporarily fit the platter, fig. 4(1), to its centre spindle, place a record on the platter and fit the template protractor fig. 1(21), to the centre spindle. With the stylus tip resting on the point marked —O—, the arm should be mounted so as to ensure that the front part of the arm tube and the headshell are parallel to the lines on the protractor. Mark the Fluid Arm mounting hole centre, remembering that although the hole can be in any convenient position around the platter, it must be possible to close the perspex cover without fouling the counterweight overhang.
- 3** Drill a 1 in. (25 mm) diameter mounting hole for the Fluid Arm.
NOTE: (i) The exact positioning of the hole is not critical since with a hole of this size there will be a total of $\frac{1}{2}$ in. (13 mm) movement in all directions for final adjustment.
(ii) A pre-drilled tone arm board for each fluid arm length is available if required.
- 4** Fit the Fluid Arm to the tone arm board. The base nut assembly, fig. 1(2), should be "finger tight" only.
- 5** Connect the earth tag, fig. 1(20), to the screw on the lower base nut.
NOTE: On some models there is no earth tag, in which case earthing is not required.
- 6** Using "Evostick" (or a similar adhesive), glue the tone arm board onto the four sponge rubber pads ensuring that its edges do not touch the motorboard.
- 7** Proceed now with the installation instructions for the Hydraulic Reference Turntable.

Hydraulic Reference Turntable—installation instructions

- 1** Temporarily remove the perspex cover by pulling out the hinge rod.

- 2** Fill the fluid well, fig. 3(2), surrounding the main bearing, fig. 3(1), with the fluid supplied in the large bottle. All the fluid should be used.

NOTE: (i) The fluid will flow more easily if the bottle is first warmed in hot water.

(ii) In the event of spillage the fluid can be cleaned up using a spirit or petroleum-base solvent.

CAUTION: ONCE THE WELL HAS BEEN FILLED THE TURNTABLE MUST NOT BE TILTED OR THE WELL SPUN AT HIGH SPEED.

- 3** Ensure that the speed control vane, fig. 3(3), is immersed in the fluid.

- 4** Secure the platter, fig. 4(1), to the centre bearing with the knurled retaining nut, fig. 4(2), after first ensuring that the mating surfaces are clean.

CAUTION: (i) THE KNURLED RETAINING NUT SHOULD BE TIGHTENED ONLY "FINGER TIGHT". DO NOT USE FORCE ON THIS NUT AS THIS MAY DAMAGE THE MAIN SPINDLE ASSEMBLY.

(ii) IF AT ANY TIME THE MAIN BEARING SPINDLE SHOULD BE REMOVED, TAKE CARE NOT TO LOSE THE THRUST BALL.

- 5** Ensure that the motor assembly, fig. 3(4), is floating correctly and that its three support springs, fig. 3(5), are seated in their cups correctly. Any temporary misalignment that may have occurred during transit can be corrected simply by holding the motor under the motorboard and pulling it downwards.
- 6** Lightly oil the stroboscope spindle and then fit the stroboscope, fig. 3(6), onto its bearing.
- 7** Fit the drive belt, fig. 2(2), as shown in fig. 2.
- 8** Ensure that the mains voltage adjustment plug, fig. 3(7), has been set for the correct voltage, and that a fuse, fig. 3(8), of the correct rating has been fitted.

- 9** Assemble the top plate, fig. 4(3), onto the unit and secure it with the three retaining nuts, fig. 4(4).
- 10** Refit the perspex cover.
- 11** Close the cover and level the unit by means of the three adjustable legs, using the bubble level indicator, fig. 4(6), on the motorboard.
- 12** Connect the a.c. mains to the plug provided underneath the motorboard.
- 13** Proceed now with the setting-up of the Fluid Arm.

Fluid Arm—setting-up instructions

- 1** Fit the cartridge (see operation 1 in the above Fluid Arm fitting instructions).
- 2** Place a record on the platter and fit the template protractor, fig. 1(21), to the platter centre spindle. With the stylus tip resting on the point marked —O—, move the Fluid Arm in its fixing hole so as to ensure that the front part of the arm tube and the headshell are parallel to the lines on the protractor. Tighten the base nut, fig. 1(2), "finger tight".
- 3** Slacken the height adjustment screw, fig. 1(3), in the base nut assembly and adjust the height of the arm tube so that it is parallel to the record when playing. Tighten the height adjustment screw.
- 4** Fit the eccentric counterweight, fig. 1(9), on the arm between the helmet, fig. 1(5), and the screwed counterweight fig. 1(10), and then move the counterweight forward or backward to obtain static balance. Rotate the counterweight to obtain lateral balance so that the helmet runs vertically whilst playing.
- 5** Using the TRANSCRIPTOR Stylus Scales (see operating instructions below), adjust the screwed counterweight, fig. 1(10), to obtain the correct tracking weight as stated by the cartridge manufacturer (always use the lowest stated tracking weight).

- 6** Using the template protractor, make a final adjustment for tracking error. Fine adjustment can be made by means of the set screw, fig. 1 (4), at the end of the arm. This screw provides radial and slight longitudinal adjustment and care must be taken to ensure that after any adjustment the top of the headshell is still parallel in both planes with respect to the record, with the helmet, fig. 1 (5), held in a vertical position (i.e. normal playing condition).
CAUTION : THERE IS NOT MORE THAN $\frac{1}{8}$ in. (8 mm) LONGITUDINAL ADJUSTMENT OF THE HEADSHELL. GREATER MOVEMENT WILL RESULT IN SEVERING THE VERY FINE WIRING INSIDE THE ARM.
- 7** Carefully tighten the base nut assembly by using a small screwdriver as a lever inserted in one of the three radial holes in the base nut.
- 8** Note the position of the index marks, fig. 1 (8), on the helmet cap, fig. 1 (6), and helmet, fig. 1 (5), remove the helmet cap retaining screw, fig. 1 (7), and then lift out the helmet cap. With the pivot, fig. 1 (18), still in position, fill the fluid well, fig. 1 (19), from the small bottle of fluid to about $\frac{1}{16}$ in. (1.5 mm) below the rim of the well (this is best performed by first warming the bottle in hot water and using an eye-dropper or similar device). Carefully refit the helmet cap, realigning the index marks and refitting the retaining screw. Ensure that the screw passes through the hole in the helmet cap and bears against the top of the pivot.
NOTE : The pivot fits pointed end downwards.
- 9** Place the Fluid Arm assembly in its normal rest position, with the arm supported in the groove on the lowering handwheel cradle, fig. 1 (12).
- 10** Connect the adjustable bias weight, fig. 1 (14), to the helmet with cotton thread. One end of the thread connects to the split pin, fig. 1 (15), and the other end to the screw, fig. 1 (16), on the side of the helmet. With the arm in the rest position, the bias weight must be horizontal.

- 11** Using a blank disc (i.e. no groove) at $33\frac{1}{3}$ r.p.m., adjust the bias weight in or out as required to correct any tendency for the stylus to skate on the disc.
- 12** Repeat all of the above fine adjustments to ensure that the Fluid Arm has been set-up correctly.
- 13** Connect the two co-axial plugs to the reproducing equipment as follows:
 - (i) Red to right hand channel.
 - (ii) Black to left hand channel.
- 14** Proceed now with the setting-up of the Sweep Arm.

Sweep Arm—setting-up instructions

NOTE: The Sweep Arm is available separately as an accessory. If the sweep arm, (fig. 5) has not been fitted by the manufacturer, a pre-drilled fixing hole blanked off with a chromium screw, fig. 4(7), will be found on the left hand side of the motorboard. Remove this screw, insert the sweep arm support rod and secure with its wing nut under the motorboard.

The correct setting for the Sweep Arm is adjusted initially by the manufacturer. Slight readjustment will be necessary only after considerable use or after renewing a brush.

- 1** Slacken the conical lifting nut, fig. 5(1), and place the brush on the record.
- 2** Ensure that the brush is running vertically whilst in use. If necessary make a slight adjustment to the height of the brush by trimming away part of the plastic sheathing, fig. 5(2), around the support rod with a sharp knife or razor blade, and then tightening the securing nut under the motorboard.
- 3** Using the TRANSCRIPTOR Stylus Scales (see operating instructions below) adjust the balance nut, fig. 5(3), on the end of the Sweep Arm for a brush downward force of between 0.5 and 0.75 gramme.

Stylus Brush—setting-up instructions

NOTE: The Stylus Brush is available separately as an accessory.

If the stylus brush (fig. 5) has not been fitted by the manufacturer, a pre-drilled hole blanked off with a chromium screw, fig. 4(8), will be found on the right hand side of the motorboard. Remove this screw, insert the stylus brush support rod and secure with its wing nut under the motorboard.

The stylus assembly should pass through the brush about half way up its length. If necessary, adjust the brush height by trimming away part of the plastic sheathing, fig. 5(4), around the support rod with a sharp knife or razor blade, and then tightening the securing nut under the motorboard.

Stylus Scales—operating instructions

NOTE: The Stylus Scales are available separately as an accessory.

The scales should be placed on a record on the platter and must always be used at right angles to the arm being set-up.

- 1** Place the weight(s) equal to the required downward force centrally on the rubber pad, fig. 6(1), on the scales, stacking the weights carefully if more than one is required.
- 2** Balance the scales by means of the knurled adjustment nut, fig. 6(2), until the bubble indicator, fig. 6(3), is centrally positioned.
- 3** Remove the weights and place the stylus tip on the rubber pad.
- 4** Adjust the counterweight on the fluid arm, or stylus brush, until the bubble is once again centrally positioned.

NOTE: An error of only 100 milligrammes is sufficient to deflect the bubble completely off the scale.

Hydraulic Reference Turntable—operating instructions

Once it has been correctly set-up, the TRANSCRIPTOR equipment is extremely simple to use. The following are a series of guidance notes and general operating instructions.

1 Running-in.

The turntable will possibly run slightly slow when new. Therefore, a continuous running-in period of about 36 hours is recommended.

2 Switching on and off and speed control.

The turntable drive is switched on or off simply by rotating the knob, fig. 4(9), on the top plate through 90°.

Fine speed control is by means of the hydraulic damping vane, fig. 3(3), the control knob for which is on the right-hand side of the platter. Switching between 45 r.p.m. and 33½ r.p.m. is by means of the knob, fig. 4(5), protruding through the top plate—push down for 45 r.p.m., pull up for 33½ r.p.m. This speed change operates only while the motor is running.

3 Fluid Arm operation.

With the arm resting in the groove on the lowering handwheel cradle, fig. 1(12), and the lowering handwheel, fig. 1(11), in its raised position, swing the entire assembly around until the desired position on the record is reached. Turn the handwheel in a counter-clockwise direction until a point is reached when it will lower automatically. If required, however, the hydraulic action of the handwheel can be over-ridden and it can be manually rotated instead. Once the stylus is on the record, swing the assembly back towards the front again in order to ensure correct bias compensation.

To lift the stylus off the record, swing the assembly in again and lift the arm on the larger diameter section of the cradle (not in the groove as this may cause a sideways force on the stylus). Once lifted, slide the arm into the cradle groove and swing the entire assembly back to the normal rest position. Positioning damping is provided by means of a knurled screw, fig. 1(17).

The lowering handwheel swings over an arc of approximately 90°. If required, this arc can be reset by adjusting a set screw, fig. 1(13), and moving the handwheel over the desired arc.

4 Always close the cover over the equipment while playing.

5 Record cleaning.

When using the TRANSCRIPTOR Fluid Arm, never use an impregnated cloth or antistatic fluid to clean records as these leave a deposit in the record grooves. Any advice to the contrary must be ignored. Use only the Sweep Arm, and use it always at each playing. The brush should then be flicked gently after each playing to release the dust collected. In the event of the brush becoming too dry it may track too quickly towards the record centre, in which case it must be damped slightly with plain water.

Should the Sweep Arm fail to remove any spots or dirt on the record, the record should be wiped lightly in a circular direction following the grooves with a soft cloth and clean water.

When using the Sweep Arm always ensure that there is a gap between the main beam and the top of the conical lifter nut, fig. 5(1). To park the Sweep Arm when not in use, simply screw the conical nut up again.

CAUTION : SWING THE SWEEP ARM CLEAR OF THE RECORD BEFORE LIFTING THE PERSPEX COVER.

6 Stylus cleaning.

The stylus brush should be used before every playing of a record in order to ensure the maximum performance that the delicate cartridge assembly can achieve.

Hold the headshell in its rest position with the left hand. Then with the right hand, revolve the stylus brush first in a counter-clockwise direction so that the brush passes from back to front of the cartridge and then back again in the opposite direction. This will ensure that every particle of fluff and dust is removed from the stylus.

Routine maintenance and cleaning

Routine maintenance of the TRANSCRIPTOR equipment is limited to only three items :

- 1** Periodically examine the drive belt, fig. 2(2), for signs of perishing or cracking. Renew if necessary.
- 2** Every 12 months, lightly oil the stroboscope and main bearings (use a sewing machine oil, or similar). Access to the main bearing is obtained by removing the platter, fig. 4(1), sliding the speed control vane, fig. 3(3), to one side and lifting out the fluid well, fig. 3(2).

NOTE: To remove platter, remove belt, fig. 2(2); unscrew platter retaining nut, fig. 4(2), then, placing fingers of both hands beneath rim and one thumb on main bearing, fig. 3(1), lift with fingers and press down on main bearing. To prevent damage to the fluid well and the speed control vane a mating paper washer "weak link" is fitted between the platter mounting spindle and the fluid well.

CAUTION: ENSURE THAT THERE IS NO HYDRAULIC FLUID ON THE UNDER SURFACE OF THE FLUID WELL OR ON THE FACE OF THE MAIN BEARING. IF ANY FLUID IS SPILLED, CLEAN UP IMMEDIATELY USING A SPIRIT OR PETROLEUM-BASE SOLVENT.

- 3** Whenever it starts to show signs of wear, turn the Sweep Arm brush round in its holder. This is done by unscrewing the brush holder from the arm and pulling the brush out.

Cleaning, other than daily dusting, should be carried out using a spirit or petroleum-base cleaning fluid on the metal parts and a warm, mild detergent solution on the plastic parts (e.g. the stroboscope and the perspex cover). Do not use an abrasive polish on any part of the equipment.

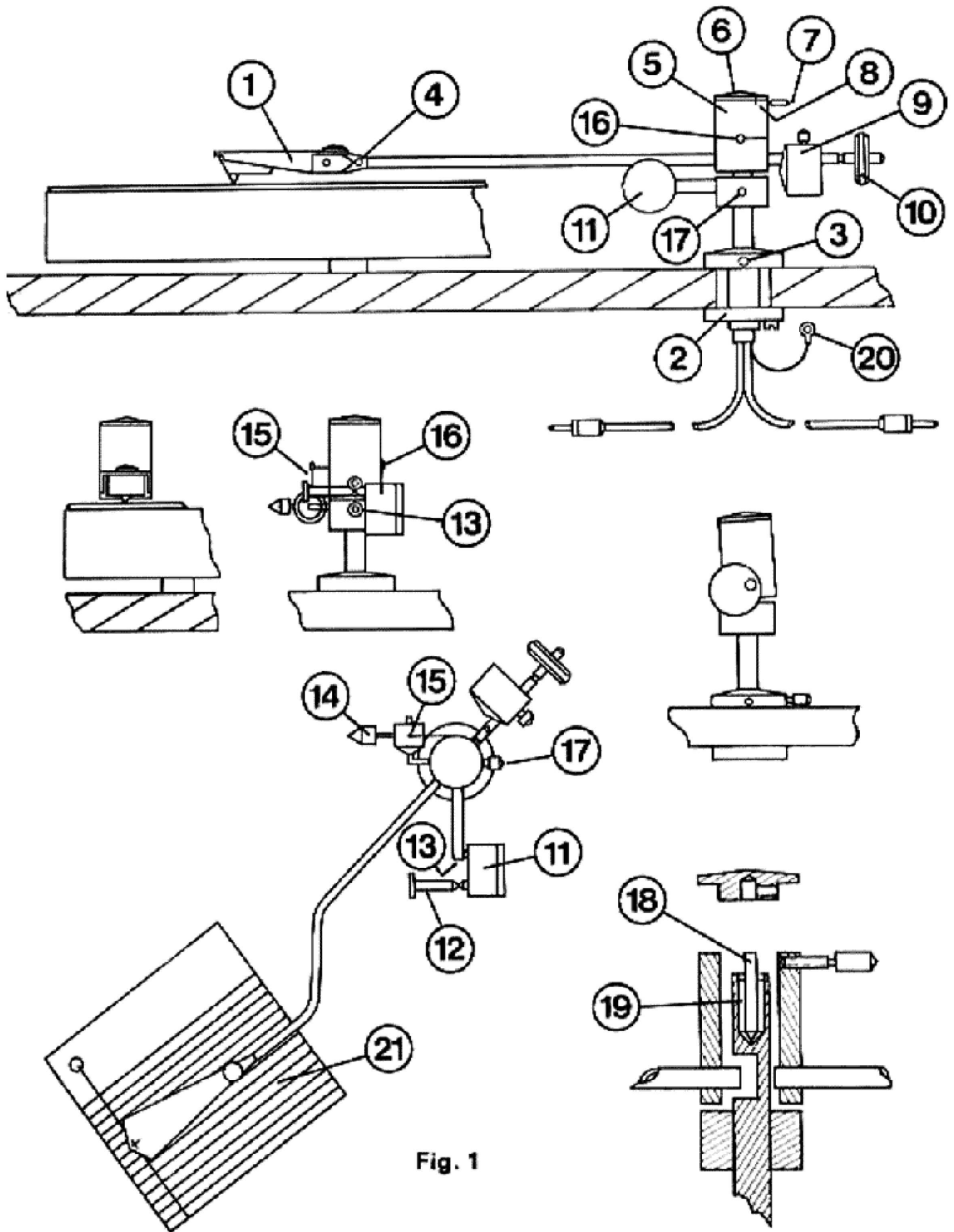

Fig. 1

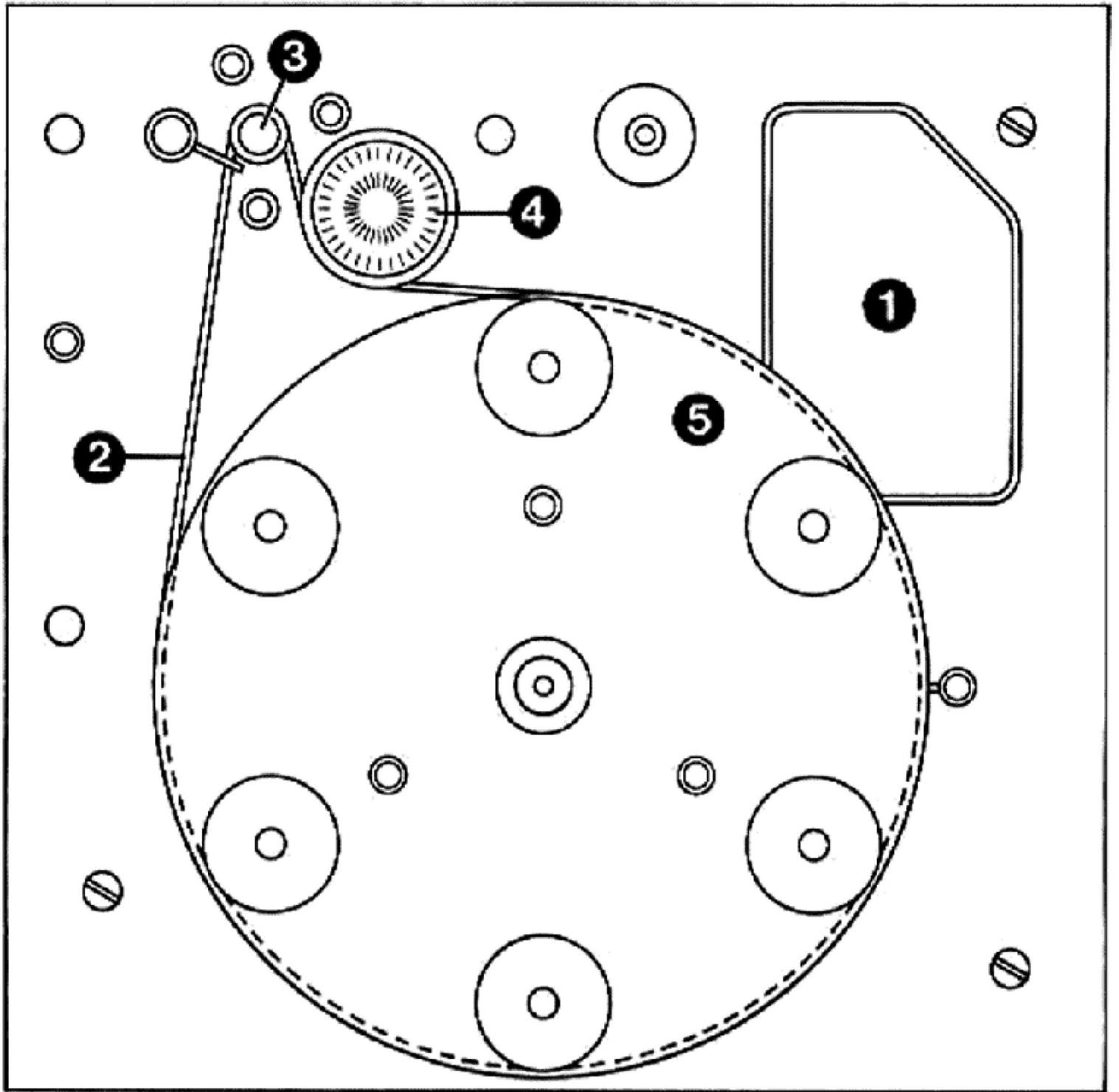

Fig. 2

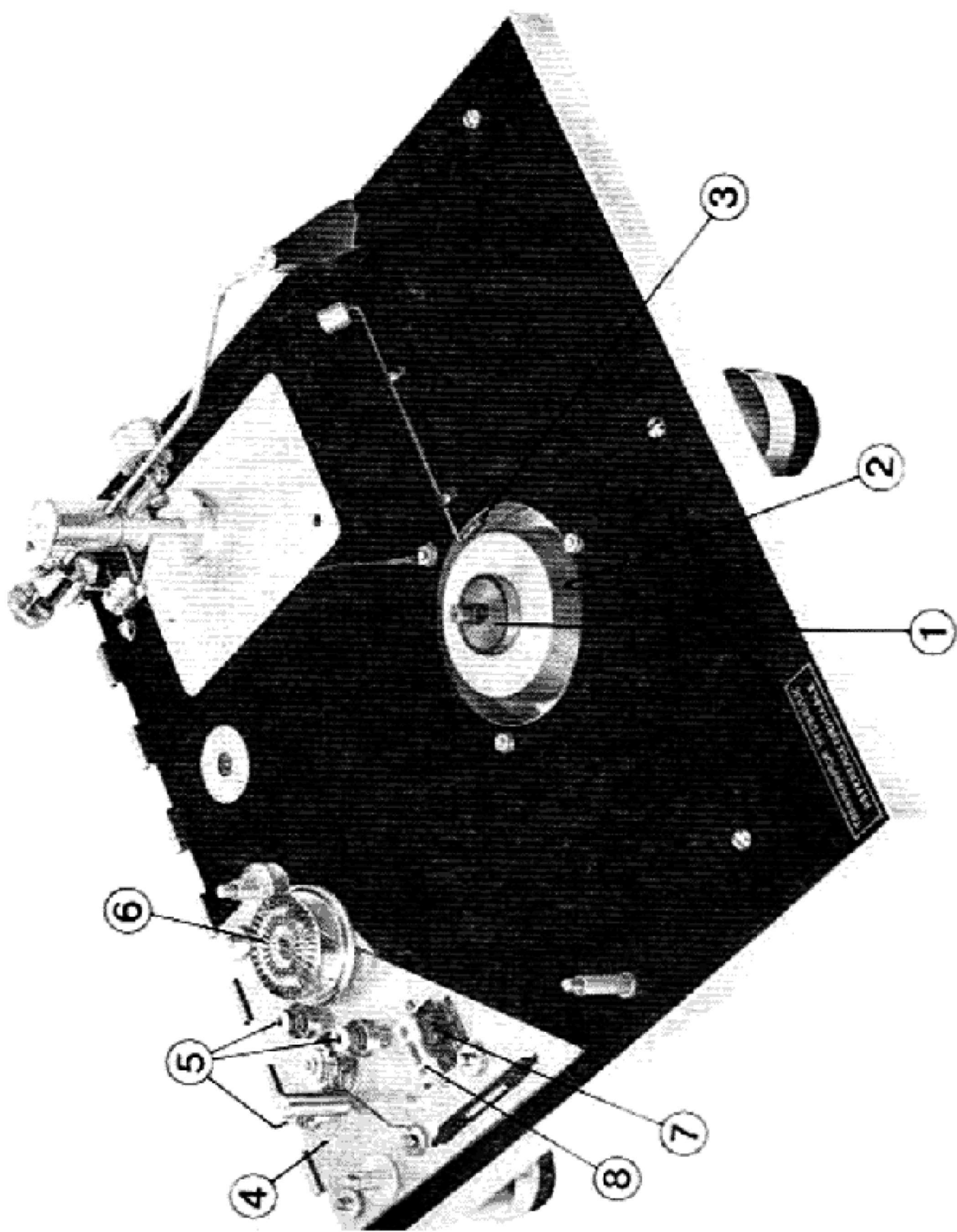

Fig. 3

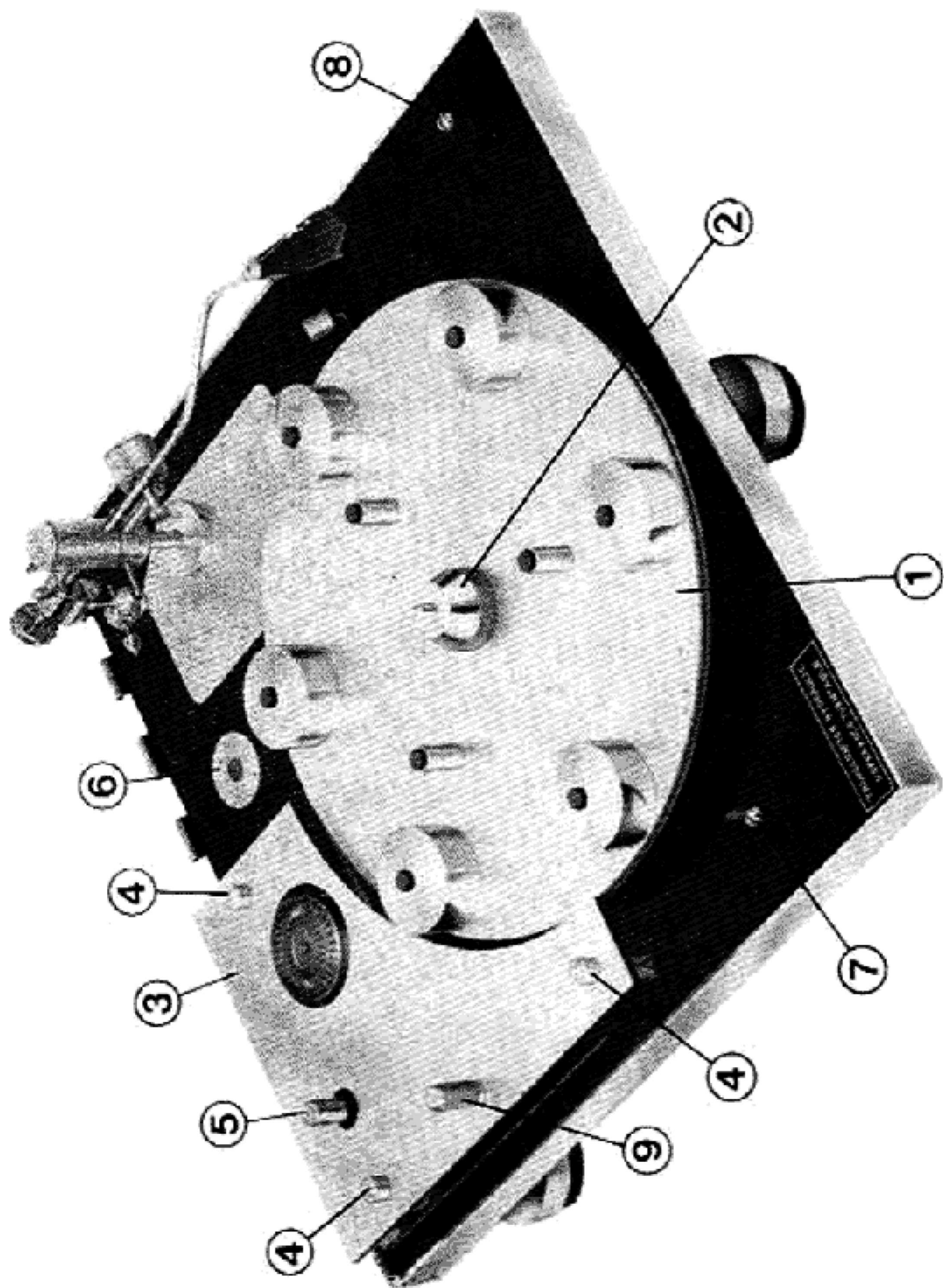

Fig. 4

